

# MANHOLE CLEANER

- ✓ With protection plate
- ✓ Optimal cleaning of vertical main
- ✓ Easy to use

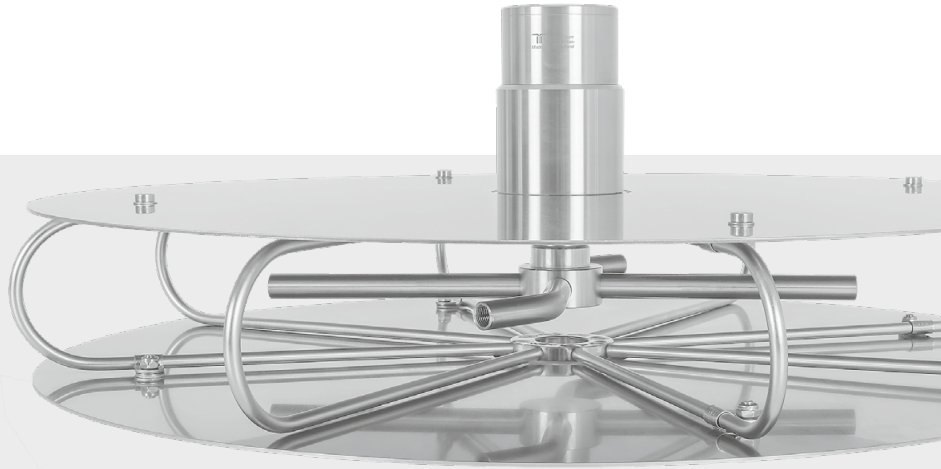

Mosmatic Manhole cleaner is ideal for the restoration, cleaning and service of manholes, liftstations and other long verticle drops. Easy to use self rotating equipment made for higher flow rates. Stainless Steel protection plate included. Choose from a variety of sizes.



### TECHNICAL DATA

**Pressure** 2500 psi  
**Temperature** 250°F  
**Inlet** 1/2" NPTF (TXS-2f)  
 1" NPTF (TXS-4f)  
**Body** stainless steel  
**Nozzles\*** für 2x 1/8" (TXS-2f)  
 für 4x 1/8" (TXS-4f)  
**Throughput** ph 3 - 12

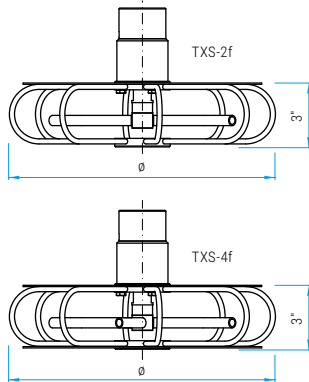

### TXS-2f with protective plate

Part No.	ø	Weight
81.037	12"	8.1 lbs
81.047	16"	9.7 lbs
81.057	20"	11.7 lbs
81.067	24"	14.1 lbs
81.087	32"	14.3 lbs

### TXS-4f with double protective plate

Part No.	ø	Weight
81.923	20"	15.4 lbs
81.928	16"	11.9 lbs

\* Nozzles not included.

**Important: Do not use unprotected!**

# SILO CLEANER

- ✓ Adjusts to your application
- ✓ Equipped with stabilizer nozzles
- ✓ Completely maintenance-free



Mosmatic has a solution for cleaning Silo's and other large diameter verticle drops. The extendable arms with rollers help guide and maintain a close surface cleaning impact. Simply attach a suspension cable to the eyelets and use your winch to raise and lower the Silo Cleaner. Stabilizer nozzles increase the cleaning distance and impact and maintain a more concentrated spray pattern. Stainless steel construction and maintenance free design help to ensure long life and reliability.



### Silo-R

Part No.	Length/Width	Height	Rotor Arm	Nozzles	Wheels	Weight
81.095	6'6"-11'6"	8"	82.9036	2x 0005 EG	4x ø4"	55 lbs

### FEATURES

#### Variable Lengths & Foldable

The length of the rotating arm is easily adjusted from 80" to 140". Folding the Silo Cleaner allows for a tight fit into the Silo loading port.

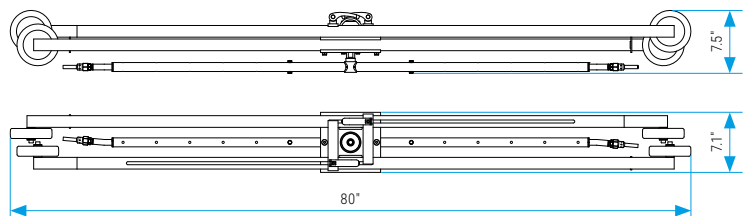
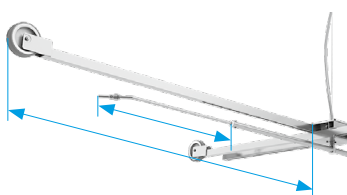

### TECHNICAL DATA

**Pressure** 4000 psi  
**Temperature** 250°F  
**Inlet** 1/2" NPTF