

- ✓ Flange for easy installation
- ✓ Seal failure warning, through weep holes
- ✓ Maintenance free
- ✓ Carbide seal system

### Application

Surface cleaners, parts washers, tire cleaners, high pressure, self rotating applications

#### TECHNICAL DATA

**Pressure** 4000 psi (27.5 MPa)  
**Temperature** 250°F  
**RPM** max. 2'000 rpm

**Body** DYF: brass, nickel plated  
 DYFI: stainless steel

**Inner part** stainless steel  
**Seal** carbide

**Bearing** 2x radial ball bearings  
 1x thrust ball bearing

**Throughput medium** pH 3 - 12  
 filtered 10 microns  
 compressed air (290 psi)

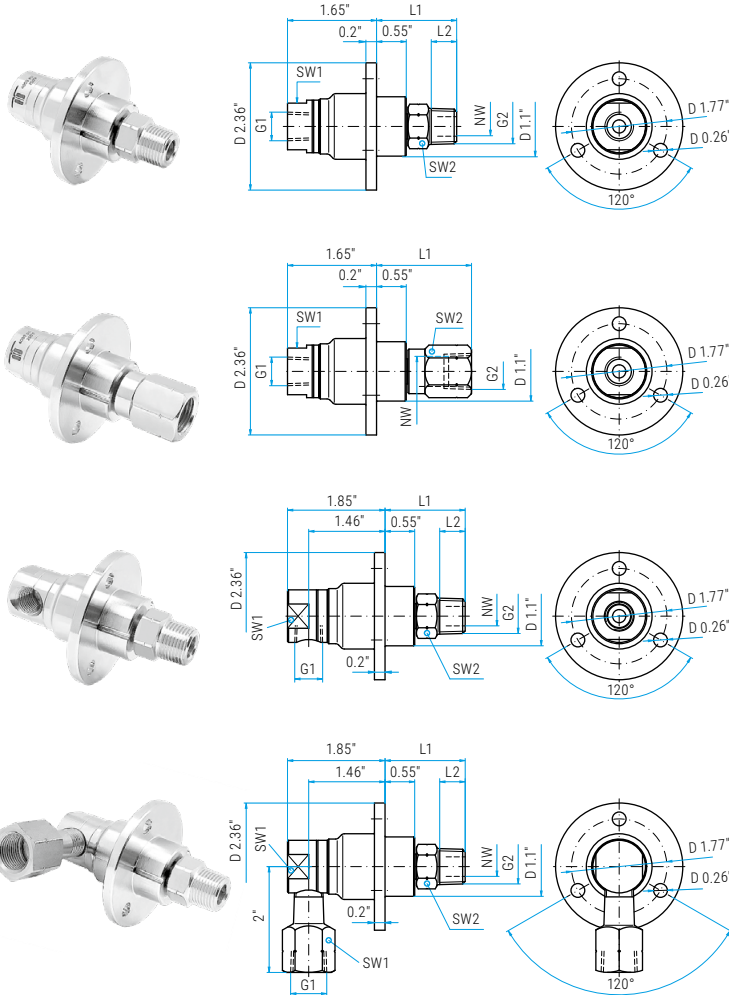
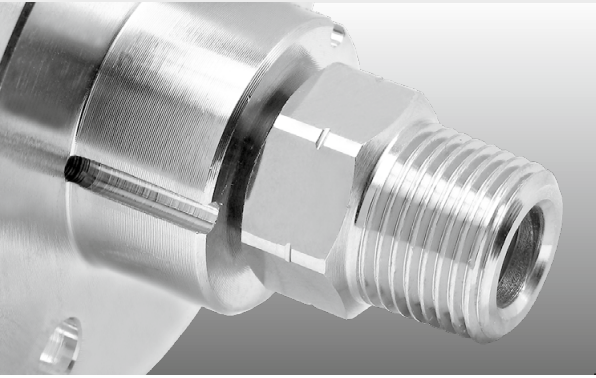
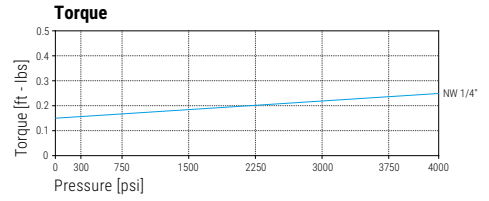
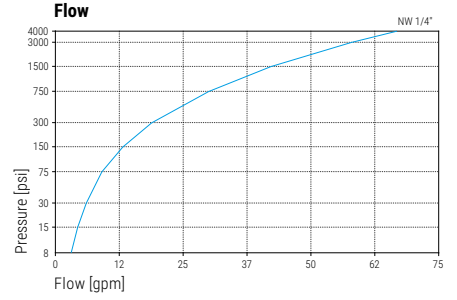

DYF		DYFI		G1 (F)	G2 (M)	NW	SW1	SW2	L1	L2	Weight
<b>58.051</b>	<b>58.056</b>	1/4" NPTF	1/4" NPTM	1/4"	0.87	0.67	1.45	0.43	10.4 oz		
<b>58.053</b>	<b>58.058</b>	1/4" NPTF	3/8" NPTM	1/4"	0.87	0.75	1.49	0.47	11.0 oz		
<b>58.063</b>	<b>58.068</b>	1/4" NPTF	G3/8" M	1/4"	0.87	0.75	1.49	0.39	13.5 oz		
<b>58.151</b>	<b>58.156</b>	3/8" NPTF	1/4" NPTM	1/4"	0.87	0.67	1.45	0.43	11.0 oz		
<b>58.153</b>	<b>58.158</b>	3/8" NPTF	3/8" NPTM	1/4"	0.87	0.75	1.49	0.47	10.4 oz		
<b>58.163</b>	<b>58.168</b>	3/8" NPTF	G3/8" M	1/4"	0.87	0.75	1.49	0.39	13.2 oz		

Part No.	Part No.	G1 (F)	G2 (F)	NW	SW1	SW2	L1	Weight
<b>58.052</b>	<b>58.057</b>	1/4" NPTF	1/4" NPTF	1/4"	0.87	0.75	1.65	11.0 oz
<b>58.054</b>	<b>58.059</b>	1/4" NPTF	3/8" NPTF	1/4"	0.87	0.87	1.76	11.0 oz
<b>58.152</b>	<b>58.157</b>	3/8" NPTF	1/4" NPTF	1/4"	0.87	0.75	1.65	11.0 oz
<b>58.154</b>	<b>58.159</b>	3/8" NPTF	3/8" NPTF	1/4"	0.87	0.87	1.76	11.0 oz

DYF 90°		G1 (F)	G2 (M)	NW	SW1	SW2	L1	L2	Weight
<b>58.351</b>	1/4" NPTF	1/4" NPTM	1/4"	0.87	0.67	1.45	0.43	13.0 oz	
<b>58.353</b>	1/4" NPTF	3/8" NPTM	1/4"	0.87	0.75	1.49	0.47	13.0 oz	

Part No.	G1 (F)	G2 (M)	NW	SW1	SW2	L1	L2	Weight
<b>58.453</b>	3/8" NPTF	3/8" NPTM	1/4"	0.87	0.75	1.49	0.47	15.0 oz
<b>58.463</b>	3/8" NPTF	G3/8" M	1/4"	0.87	0.75	1.49	0.39	16.2 oz

<b>36.905</b>	Seal kit
<b>36.906</b>	Seal kit + adhesive

WWW.MOSMATIC.COM