

SENATOR™ G2D 275-20



4000
275 BAR
PSI

20
L/PM

KOHLER KDW1003
LIQUID COOLED DIESEL
ENGINE TYPE
KOHLER.Diesel

GEARBOX
1450RPM
DRIVE

COLD
WATER
OUTPUT



HERO INNOVATIONS



TLL™
Top Lifting Lugs



PEXO™
Stainless Steel Exoskeleton



JWPP™
Jetwave Italian Premium Pump



LCE™
Liquid Cooled Diesel Engine



AVPS™
Anti Vibration Protection System



CLASS A AS/NZS 4233
HIGH PRESSURE CLEANER
NO RTO CERTIFICATION REQUIRED FOR OPERATORS



APPLICATIONS



Tradesmen



Factories & Manufacturing



Mine Sites



Offshore Oil & Gas

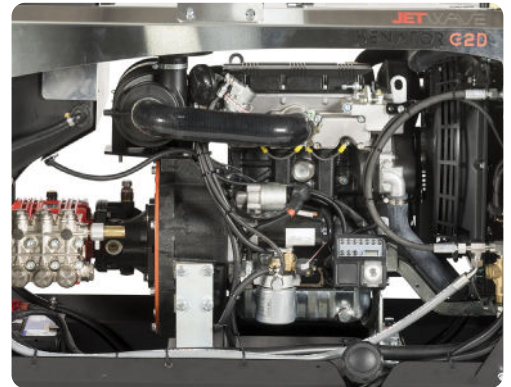
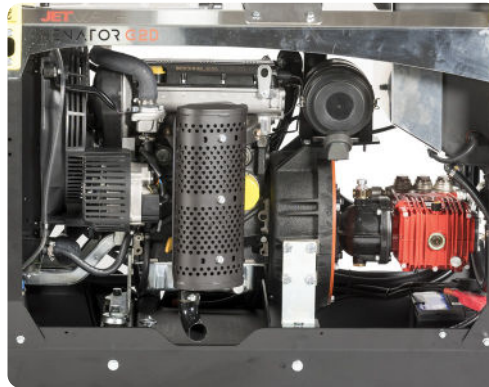

STANDOUT FEATURES



JW® UDOR® Premium Italian plunger pump running at 1450RPM, delivers more performance and longer life.



Industrial liquid cooled Kohler™ KDW1003 24HP fuel injected diesel engine, electric start with hour metre.



Jetwave Safety System™ (JSS) safety valve to prevent over pressurisation.



Seamless & sealed 40L on-board oversized water bypass tank w/low level cut out, for unit water supply and pump protection.



Battery isolator & Emergency stop for increased safety and longevity.



Seamless under chassis mounted 25L fuel tank (w/level gauge) protected from heat.

STANDARD EQUIPMENT



Gun: J5500k low trigger force gun w/swivel & lance coupling system.

Lance: JW Straight stainless steel lance w/ snap coupling + nozzle w/protector & tail



Hose: 15m non marking double wire braid hose w/M22 couplings



Chemical: JW easy foam kit w/1L bottle



G2 WASHBOX VIDEO

DIMENSIONS (MM)

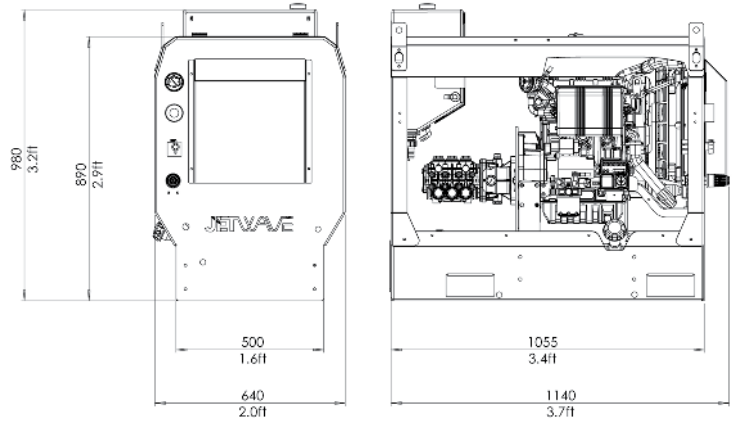

TECHNICAL DATA 0:00

SENATOR™ G2D 275-20

Product Code	CW4000-20DG2
Pressure / Flow Rate	4000 PSI (275 BAR) / 20 L/PM (1200 L/PH) / 5.3 GPM
Max Water Inlet Temp	60C°
Class (AS/NZS: 4223)	A (5,500 Bar/Litres)
Usage Frequency	Professional: 4 Hours Daily
Nozzle Size	05
Frame Structure	CNC Modular galvanised steel chassis plus satin powder coat finish and stainless steel cover

MOTOR FEATURES

Engine / Power	Kohler™ KDW1003 Electric Key Start (3 cylinder liquid cooled) 24HP / 1028cc
Fuel Type / Capacity / Protection	Diesel / 25L (w/level gauge) / Low Oil Shutdown

HYDRAULIC FEATURES

Pump / Head / Pistons	JW® UDOR® Premium Triplex Plunger / Brass (Nickle Plated) / Ceramic
Motor Pump Coupling / Pump RPM	Gearbox Drive / 1450RPM
Unloader Valve	Independent
Safety Valve	Yes

DIMENSIONS & WEIGHT

Machine Dimensions / Weight	Skid: 1140mm(L) x 640mm(W) x 980mm(H) / 280KG (approx.)
-----------------------------	---

WARRANTY(S)

Unit / Pump Warranty*	 2 Years
Engine Warranty*	KOHLER .Diesel 3 Years

OPTIONAL ACCESSORIES

OPTIONAL UPGRADES

30m Hose Reel w/30m hose	1060CMPL-SD30M	4 Wheel Trolley Kit (2xCastor Wheels 2xOff Road Wheels)	JWA407E
60m Hose Reel w/60m hose	1067CMPL-SD60M	Mine Specification Kit	G2DMINESPEC-A
JW Pro Turbo Head	JWA303-05		
21" Hammerhead FSC - Stainless Steel	JWA-FSC22-5.05		

Copyright © 2023 Jetwave® Group Pty Ltd. All Rights Reserved.

The manufacturer reserves the right to modify design features and technical facts without notice, due to our principals of continuous improvement.

*Coverage against defects in material and workmanship (refer to Jetwave's and component partners T&Cs).

V3.0 08/23